

Make2Pack Meeting Notes – May 19, 2005 in Atlantic City NJ

Vertical Form Filler and Seal - Intermittent Motion

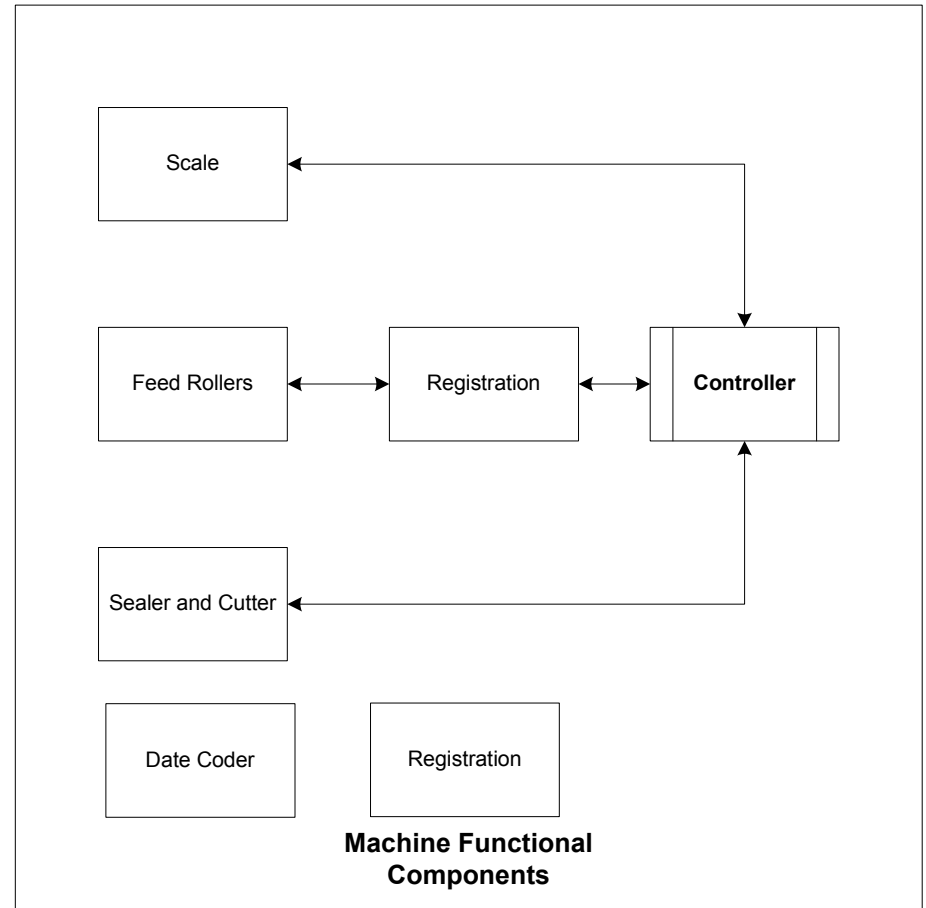

Vertical Form Filler and Seal - Intermittent Motion

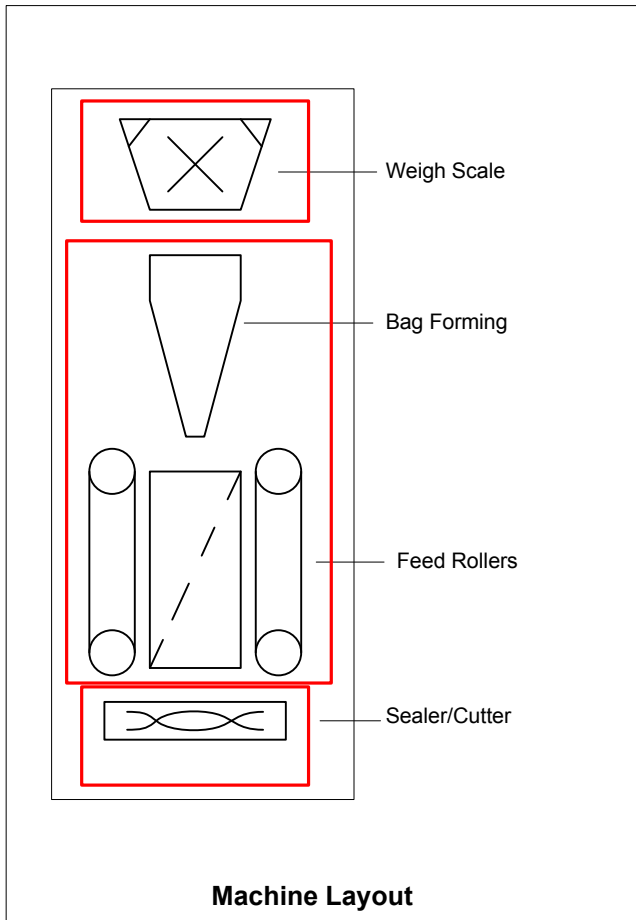
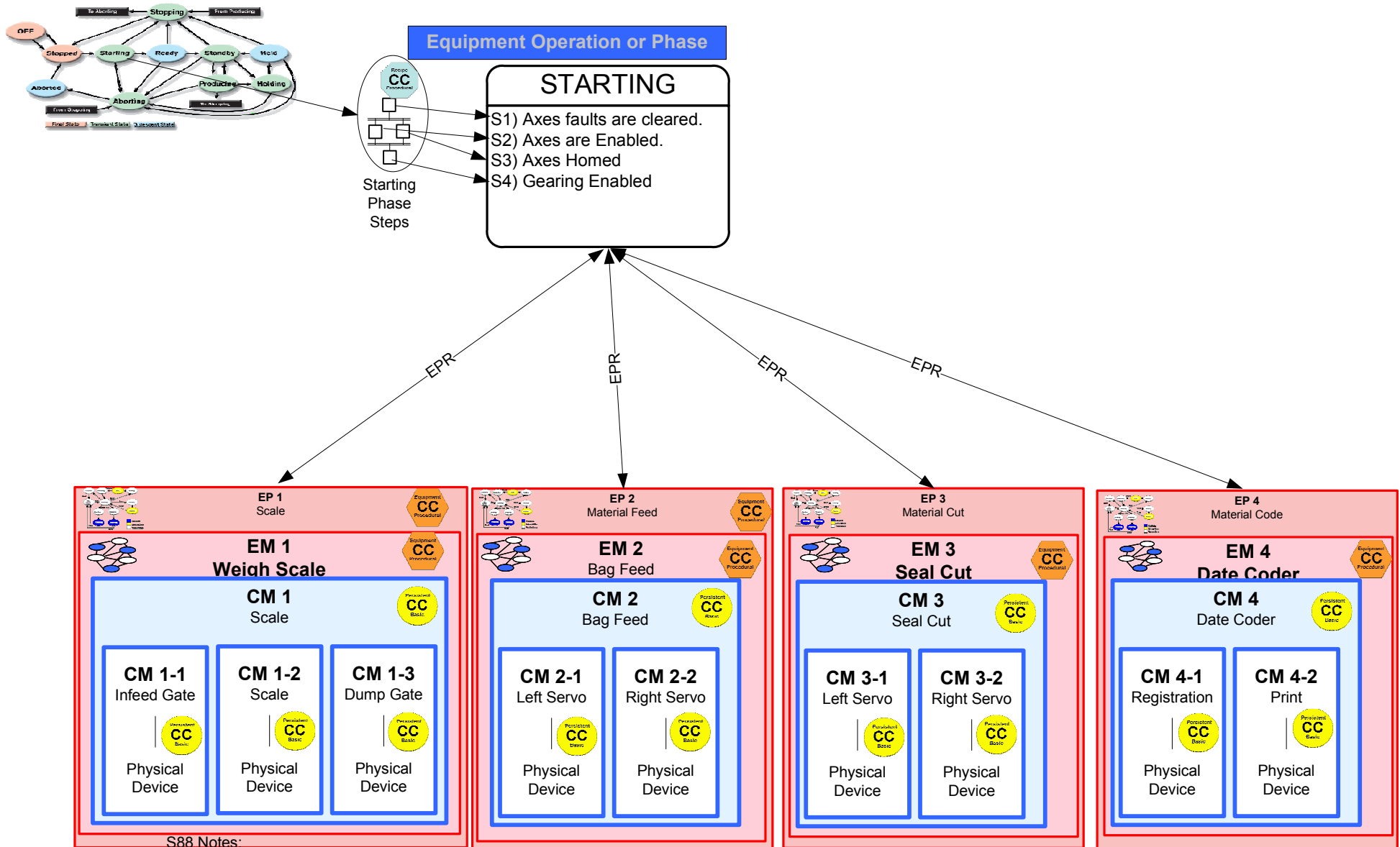

S88 Notes:

CC is Component of Control it is Yellow indicating that it is persistent control
 Orange indicates it is Equipment Procedural Control.
 Blue is Recipe Procedural Control.

- An equipment phase may exist within a unit or an equipment module. An equipment phase may act on equipment modules(s) and/or control module(s).
- A recipe procedural element (recipe phase) is independent of the equipment on which it will execute.
- A equipment procedural element (equipment phase) is specific to a piece of equipment.